



**IT** Ponte sollevatore elettroidraulico a forbice per moto.

**EN** Electro-hydraulic scissor platform lift for motorbike.

**FR** Pont élévateur électro-hydraulique à ciseaux pour moto.

**DE** Elektrohydraulische Scherenhebebühne für Motorräder.

**ES** Elevador electro-hidráulico de tijera para motocicletas.

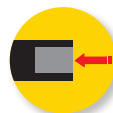

**IT** Vano posteriore a scomparsa, a scorrimento su rulli in teflon.

**EN** Retractable compartment, sliding on teflon rollers.

**FR** Compartiment arrière ouvrable à tiroir, glissants sur rouleaux en teflon.

**DE** Integrierte Klappe für radwechseln, verschiebbar auf Teflon Rollen.

**ES** Compartimento trasero, con apertura de tapa deslizante, sobre colchones en Teflon.



**IT** Predisposizione per montaggio pedane laterali di sollevamento QUAD.

**EN** Ready for mounting special platforms for lifting QUADS.

**FR** Prédiposition pour le montage des plates-formes latérales pour QUAD.

**DE** Vorrichtung zur Montage des Verlängerungen für QUAD.

**ES** Predisposición para el montaje de plataformas laterales de elevación QUAD.



## Caratteristiche • Features • Fonctions • Funktionen • Funciones

### IT Centralina di comando mobile.

- EN** Portable control unit.  
**FR** Pupitre de commande mobile.  
**DE** Tragbare Steuereinheit.  
**ES** Unidad de mando móvil.

### IT Rampa di salita a scomparsa.

- EN** Retractable drive-on ramp.  
**FR** Rampe d'accès rétractable.  
**DE** Versenkbare Auffahrrampe.  
**ES** Rampa de subida ocultable.

### IT Vaschetta porta utensili laterale.

- EN** Side tool tray.  
**FR** Porte-outil latéral.  
**DE** Seitlich montierte Schale für Kleinteile.  
**ES** Bandeja porta-útiles lateral.

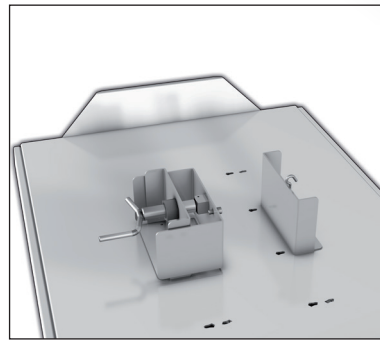

### IT Fornito con morsa stringiruota manuale.

- EN** The lift is provided with manual clamp for front wheel fixing.  
**FR** Le pont est livré avec serre-roue manuelle.  
**DE** Mit manueller Radklemme.  
**ES** Se suministra con mordaza bloqueo de rueda manual.

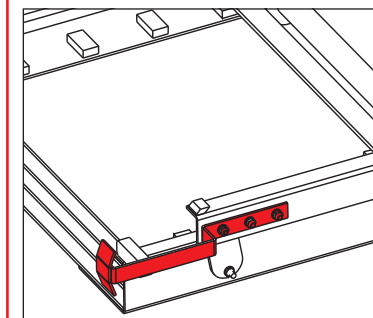

### IT Sicurezza meccanica con sblocco a pedale.

- EN** Mechanical safety device with unlocking by pedal.  
**FR** Sécurité mécanique avec déblocage à pédalé.  
**DE** Mechanische Sicherheitsvorrichtung mit Pedalfreigabe.  
**ES** Seguridad mecánica con desbloqueo por pedal.

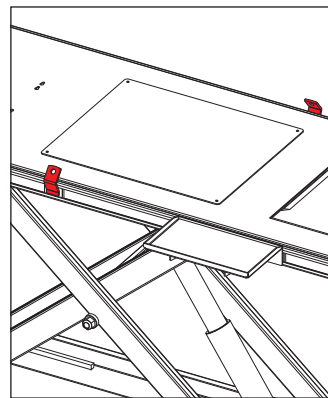

### IT Fornito con bande laterali scorrevoli per fissaggio cinghie.

- EN** Standard supplied with sliding side-bands for belts fastening.  
**FR** Livré avec crochets laterals pour fixer les courroies.  
**DE** Geliefert mit seitlichen Stützen für die Befestigungsriemen.  
**ES** Se suministra completo de gancios laterales por fijar las correas.

### IT Valvola controllo velocità di discesa.

- EN** Safety valves to check the descent speed.  
**FR** Soupape de sécurité pour le contrôle vitesse de descente.  
**DE** Ventil zur Kontrolle der Senkgeschwindigkeit.  
**ES** Válvula de control de la velocidad de descenso.

## Accessori Opzionali • Optional Accessories

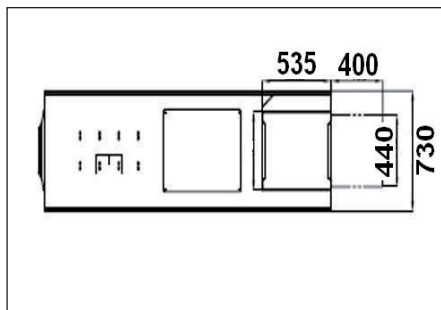
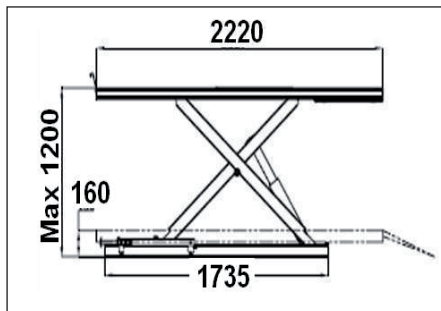

### COD. 25100030

#### IT Bloccaggio ruota anteriore manuale.

- EN** Front manual clamp.  
**FR** Système blocage manuel roue avant.  
**DE** Vordere manuelle Klemme.  
**ES** Sistema de bloque manual rueda delantera.

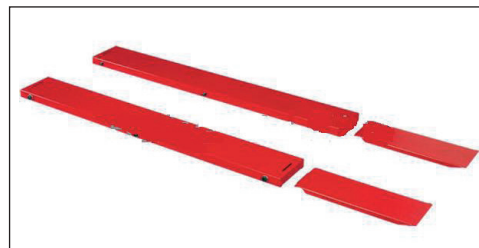

### COD. 25100031

#### IT Pedane laterali per sollevamento QUAD.

- EN** QUAD side-platforms.  
**FR** Plate-formes latérales pour QUAD.  
**DE** Seitliche Verlängerungen für QUAD.  
**ES** Plataformas laterales para QUAD.

## Dati tecnici • Technical data • Données techniques • Technisches Daten • Datos técnicos

<ul style="list-style-type: none"> <li>• Portata massima</li> <li>• Capacity</li> <li>• Capacité de charge</li> <li>• Tragfähigkeit</li> <li>• Capacidad</li> </ul>	<ul style="list-style-type: none"> <li>• Altezza max</li> <li>• Maximum height</li> <li>• Hauteur maxi</li> <li>• Maximalhöhe</li> <li>• Altura máxima</li> </ul>	<ul style="list-style-type: none"> <li>• Altezza min</li> <li>• Minimum height</li> <li>• Hauteur minimum</li> <li>• Minimalhöhe</li> <li>• Altura mínima</li> </ul>	<ul style="list-style-type: none"> <li>• Alimentazione</li> <li>• Power supply</li> <li>• Alimentation</li> <li>• Stromversorgung</li> <li>• Alimentación</li> </ul>	<ul style="list-style-type: none"> <li>• Tempo di sollevamento</li> <li>• Lifting time</li> <li>• Temps de soulèvement</li> <li>• Heben Zeit</li> <li>• Tiempo de elevación</li> </ul>	<ul style="list-style-type: none"> <li>• Peso netto</li> <li>• Net weight</li> <li>• Poids net</li> <li>• Nettogewicht</li> <li>• Peso neto</li> </ul>
700 Kg	1200 mm	160 mm	230V 50Hz 1p	40 sec	298 Kg