



F 524S - F 524S GT

CORMACH
CORREGGIO MACHINERY

IT Smontagomme automatici per autovetture e veicoli commerciali leggeri. Opera su pneumatici Low Profile e Run Flat.

EN Automatic tyre changers for cars and light commercial vehicles, suitable for Low Profile and Run Flat tyres.

FR Démonte pneus automatique pour voitures et camionnettes, qui permet de travailler sur pneus Run Flat et surbaissés.

DE Automatische Reifenmontiermaschinen für PKW und leichte Nutzfahrzeuge mit Low-Profile und Run-Flat-Reifen.

ES Desmontadora de ruedas automática para coches y vehículos comerciales ligeros.
Permite el trabajo con neumáticos Low Profile y Run Flat.



24"

IT Bloccaggio cerchi da 10" a 24".

EN Rim capacity from 10" to 24".

FR Blocage jantes de 10" à 24".

DE Felgenreterierung von 10" bis 24".

ES Bloqueo de llantas de 10" a 24".



IT Palo ribaltabile pneumaticamente con comando a pedale.

EN Pneumatic tilting column by pedal control.

FR Basculement du bras avec commande pneumatique à pédale.

DE Über Fußsteuerung pneumatisch neigbarer Ständer.

ES Columna neumática basculante con mando por pedal.



IT Cilindro stallonatore a doppio effetto.

EN Double acting bead breaker cylinder.

FR Vérin décolleur à double effet.

DE Doppelt wirkender Abdrückzylinder.

ES Cilindro destalonador de doble efecto.



F 524S GT
1PH



IT Due velocità a comando manuale.

EN Two turntable rotation speed with manual switch.

FR Deux vitesses à commande manuel.

DE Zwei manuell steuerbare Geschwindigkeiten.

ES Dos velocidades de mando manual.



F 524S
3PH 2speed



IT Pedaliera estraibile.

EN Extractable pedal unit.

FR Groupe pédalés extractibles.

DE Herausziehbare Pedaleinheit.

ES Grupo de pedales desmontable.



IT Sistema di recupero giochi.

EN Clearance regulation systems equipped with conic bushes for an easy maintenance.

FR Système de récupération des jeux.

DE Spielwiederherstellungssystem.

ES Sistema de recuperación de los juegos.



IT Versione GT dotata di dispositivo per il gonfiaggio dei pneumatici tubeless.

EN GT version equipped with the special built-in device for tubeless inflation.

FR Version GT avec gonfleur pour pneus tubeless.

DE Ausstattung der Version GT mit einer Vorrichtung zur Befüllung von Tubeless-Reifen.

ES Versión Gt equipada con dispositivo de inflado de neumáticos tubeless.

A richiesta • On request • Sur demande • Auf Anfrage • A pedido



IT Versione MI dotata di velocità di rotazione variabile (motoinverter) con comando a pedale

EN MI version with variable rotation speed (motoinverter) by pedal control

FR Version MI équipée avec vitesse de rotation variable (motoinverter), commande a pédale

DE Version MI mit variabler Rotationsgeschwindigkeit (Geschwindigkeitsinverter), Fußsteuerung.

ES Versión MI con velocidad de rotación variable (motoinverter) con mando a pedal.



IT Disponibile nella versione con dispositivo Light Now!

EN Available with Light Now! device

FR Avec dispositif Light Now!

DE Mit Light Now! Vorrichtung

ES Disponible con sistema Light Now!

Dotazione Standard • Standard Accessories

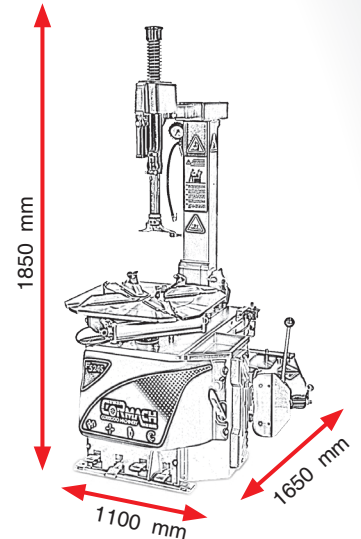

Accessori Opzionali • Optional Accessories

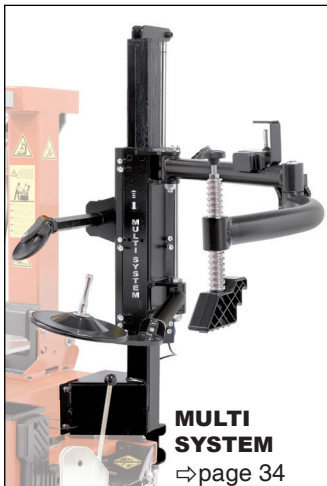

Dati tecnici • Technical data • Données techniques • Technisches Daten • Datos técnicos

• Diametro massimo ruota • Max wheel diameter	• Larghezza massima ruota • Max wheel width	• Bloccaggio esterno • Outside locking capacity	• Bloccaggio interno • Inside locking capacity	• Pressione di esercizio • Working pressure	• Alimentazione • Power supply	• Forza stallonatore • Bead breaker power	• Apertura max stallonatore • Bead breaker max opening	• Velocità di rotazione • Rotation speed	• Peso netto • Net weight
• Diamètre maximal de la roue • Max. Radaussen-durchmesser • Diámetro máx de la rueda	• Largeur maximal de la roue • Max. Reifenbreite • Ancho máx de la rueda	• Blocage extérieur • Aussenseitige Aufspannen • Para ruedas de exterior	• Blocage intérieur • Innerseitige Aufspannen • Para ruedas de interior	• Pression de travail • Betriebsdruck • Presión de trabajo	• Alimentation • Stromversorgung • Alimentación	• Force décolleur • Abdrückerkraft • Fuerza destalonador	• Ouverture maxi décolleur • Max Öffnung Abdrückschaufel • Apertura máx destalonador	• Vitesse de rotation • Dreh-Geschwindigkeit • Velocidad de rotación	• Poids net • Nettogewicht • Peso neto
1000 mm (39")	340 mm (13")	10" - 22"	12" - 24"	8 - 10 bar	230/400V 50 Hz 3ph 230V 50 Hz 1ph 230V 50-60 Hz 1ph - MI	2500 Kg	360 mm	6,5 rpm	211 Kg 222 Kg - GT